

Aarbergerweg 9  
1435 CA Rijsenhout  
P.O. Box 255  
1430 AG Aalsmeer  
The Netherlands  
Tel. +31 (0)297 219100  
www.zantingh.com  
info@zantingh.com



# INSTALLATION AND OPERATING INSTRUCTION MANUAL



## ZANTINGH CO<sub>2</sub> DOSING SYSTEM



YOU CAN COUNT ON OUR EXPERTISE

---

Dear Customer,

We would like to thank you for purchasing our product.

We provide this manual to ensure the distribution of all important information for your safety, optimal profit and product lifetime.

Please read the instructions carefully before installing or operating the product.

The safety and instructions in this manual must be followed to ensure that installation, commissioning, operation and maintenance are safe and in accordance to (local) standards and regulations.

Our technical department can provide additional information and support.

If you have any questions, please contact us.

**Phone general:** +31(0)297 – 219 100

**Phone service:** +31(0)297 – 219 125

+31(0)20 – 48 58 212 (*outside office hours*)

**E-mail:** [info@zantingh.com](mailto:info@zantingh.com)

## **CONTENTS**

	Page
<b><u>1. INTRODUCTION</u></b>	<b><u>4</u></b>
<b><u>2. DANGERS, WARNINGS AND NOTES OF CAUTION</u></b>	<b><u>5</u></b>
<b><u>3. TECHNICAL SPECIFICATION</u></b>	<b><u>8</u></b>
<b><u>4. PRODUCT DESCRIPTION</u></b>	<b><u>9</u></b>
4.1 Application	9
4.2 System components	10
<b><u>5. INSTALLATION</u></b>	<b><u>13</u></b>
5.1 Transport and preparations	13
5.2 Installation steps	14
5.3 Configuration of RWF50 modulating temperature control	15
5.4 Configuration of Vacon 100 frequency drive	16
<b><u>6. OPERATION</u></b>	<b><u>18</u></b>
6.1 First start-up	18
<b><u>7. MAINTENANCE</u></b>	<b><u>19</u></b>
7.1 Cleaning the equipment	19
7.2 Service term	19
7.3 Seasonal stop	20
7.4 Disposal	20
<b><u>8. FAILURE REPORT</u></b>	<b><u>21</u></b>
8.1 Troubleshooting	21
<b><u>9. WARRANTY CONDITIONS</u></b>	<b><u>22</u></b>

## 1. INTRODUCTION



### **IMPORTANT read this first!**

The instructions are an integral part of the product. The instructions contain important information on the commissioning, usage and operation of the product. Please read the instructions carefully.

The guarantee becomes null and void if the mounting instructions are not followed. Zantingh B.V. cannot be held liable for these damages.

Store this manual carefully near the system!

A certified heating or electrical installer should install the product, in accordance with the applicable (local) standards and regulations.

In Europe the applicable requirements are specified in:

- NEN 1010: electrical installations for low-voltage;
- NEN 3028: requirements for fuel combustion installations;
- As well as possible local regulations.

Changes to the system may only be implemented conform instructions after receiving confirmation in writing from Zantingh.



### **REMARK:**

***Restrict authorization to trained personnel only.*** Please contact your Zantingh representative or local service department in case of doubt.

## **2. DANGERS, WARNINGS AND NOTES OF CAUTION**

**NOTE:** The information included in this section is dedicated to both user and personnel charged with installation and/or maintenance

Always make sure that a copy of this manual is available in the boiler room.



### **In case of fire or any other emergency:**

When accessible close the gas valve (A1) of the gas train and switch off the main switch on the burner panel.

When there's a fire in the boiler room you need to switch off the electric power using the "fire switch" mounted on the wall outside the boiler room.

### **Before you start**

- The equipment must be installed by qualified personnel following the manufacturer's instructions, in compliance with the regulations in force.
- Qualified personnel means those having technical knowledge in the field of civil or industrial heating systems, electrical systems and are preferably employed by service centers authorized by the manufacturer.
- Before installing the equipment, make sure that the equipment rating (see equipment's name plate) is the same as delivery mains (electricity).
- Improper installation may cause injury to people and animals or damage to property, for which the manufacturer cannot be held liable.
- Remove all packaging material and inspect the equipment for integrity. In case of any doubt, do not use the equipment, but contact the supplier instead. The packaging materials (wooden crate, nails, fastening devices, plastic bags, foamed polystyrene, etc.), should not be left within the reach of children, as they may prove harmful.
- The equipment should be used exclusively for which it was designed. Any other use shall be considered as improper and therefore dangerous.
- Only equipment designed according to the regulations in force should be used.
- Failure to comply with the above instructions is likely to impair the equipment's safety.

### **Precautions if you smell gas:**

1. Immediately open doors and windows to create an air flow to purge the room
2. Close the gas valves
3. Do not operate electric switches, the telephone, or any other item likely to generate sparks
4. Contact qualified personnel

### Special instructions with regard to electric power

- The equipment must be installed and efficiently earthed as required by current safety regulations.
- It is vital that all safety requirements are met. In case of any doubt, ask for an accurate inspection of electricians by qualified personnel. The manufacturer cannot be held liable for damages that may be caused by failure to correctly earth the equipment.
- Do not use gas pipes to earth electrical equipment.
- Qualified personnel must inspect the system to make sure that it is adequate to take the maximum power used by the equipment as shown on the equipment's name plate. In particular, make sure that cable cross sections of power cables are adequate for the power used by the equipment.
- No adaptors, multiple outlet sockets and/or extension cables are allowed to connect the equipment to the electric mains.
- The use of any power-operated components implies observance of a few basic rules, for example:
  - do not touch the equipment with wet or damp parts of the body and do not work on the equipment on bare feet;
  - do not pull electric cables;
  - do not leave the equipment exposed to weather conditions (rain, sun, etc.) unless expressly required to do so;
  - do not allow children or unexperienced persons to use or work on the equipment;
- The electric cables shall not be replaced by the user. In case of damage to a cable, switch off the unit and contact qualified personnel to replace it.
- When the equipment is to remain idle or not in use for some time, the electric switch supplying all the power-driven components in the system (i.e., pumps, burner, etc.) should be switched off.



### Instructions regarding operation and maintenance

- The equipment shall be operated and serviced by qualified personnel only and in compliance with the regulations in force.
- Make sure that the equipment has been firmly secured.
- After installing the equipment, the associated burner system has to be re-commissioned, due to altered back pressure. Installation and commissioning shall only be done by qualified personnel.
- To ensure equipment efficiency and proper operation, it is essential that maintenance operations are performed by qualified personnel at regular intervals, following the manufacturer's instructions.
- Before any cleaning or servicing operation, disconnect the system from the power mains by turning the master switch OFF.
- Observe caution with hot components. They become hot during operation and will remain hot for some time after the system has stopped.
- In case of breakdown and/or defective operation, shut off the system from fuel and electricians. Make no attempt to repair the equipment or take any other action. Contact qualified personnel instead.
- Equipment shall be repaired exclusively by a servicing center, duly authorized by the manufacturer, with original spare parts and accessories.

- When a decision is made to discontinue the use of the equipment, those parts likely to constitute sources of danger shall be made harmless.
- In case the equipment is to be sold or transferred to another user, or in case the original user should move and leave the unit behind, make sure that these instructions accompany the equipment at all times so that they can be consulted by the new owner and/or the installer.

**LIABILITY:**

The manufacturer shall not be held liable, by agreement or otherwise, for damages resulting from improper installation, use and failure to comply with the instructions supplied by the manufacturer. The occurrence of any of the following circumstances may cause explosions, polluting gases (example: carbon monoxide CO), burns, serious harm to people, animals and things:

- Failure to comply with one of the instructions in this chapter.
- Incorrect handling, installation, adjustment or maintenance.
- Incorrect use of the equipment or incorrect use of its parts or optional supply.

### 3. TECHNICAL SPECIFICATION

Zantingh CO<sub>2</sub> dosing systems are suitable for the distribution of flue gasses from natural gas fired boilers, CHP generators and of liquid CO<sub>2</sub> in greenhouses.

The standard version of the CO<sub>2</sub> dosing system has been designed to work under the following operating conditions:

Max. flue gas inlet temperature : 60 °C before fan inlet.  
 Motor voltage : depending on country (50/60 Hz).

#### Properties for a 50Hz Zantingh CO<sub>2</sub> fan

POWER (kW)	Flow (m <sup>3</sup> /h) <sup>1</sup>		Fan pressure (mbar) <sup>1</sup>		Diameter (mm)	
	Min.	Max.	Min.	Max.	Inlet	Outlet
2,2	1.080	2.880	27	18	280	315
3	1.080	3.240	29	19	280	315
4	1.440	4.680	35	22	280	315
5,5	1.440	5.040	36	22	280	315
7,5	2.160	7.290	44	25	280	315
11	2.880	10.800	40	26	400	400
15	3.600	12.240	48	27	400	500
18,5	3.600	14.400	50	31	400	500
22	4.500	15.300	51	33	400	500
30	5.040	21.420	64	36	500	500

1) At flue gas temperature of 40°C and installation at sea level

#### Properties for a 60Hz Zantingh CO<sub>2</sub> fan

POWER (kW)	Flow (m <sup>3</sup> /h) <sup>1</sup>		Fan pressure (mbar) <sup>1</sup>		Diameter (mm)	
	Min.	Max.	Min.	Max.	Inlet	Outlet
2,2	720	2.880	31	19	280	315
3	720	3.420	38	21	280	315
4	1.080	5.040	36	20	280	315
5,5	1.800	6.120	36	22	280	315
7,5	2.160	7.560	44	23	280	400
11	2.700	9.720	46	28	400	400
15	2.880	11.520	58	33	400	400
18,5	3.600	13.500	58	37	400	400
22	5.400	16.200	70	32	400	500
30	5.400	18.360	73	41	400	500

1) At flue gas temperature of 40°C and installation at sea level

The outlet diameter (mm) of the CO<sub>2</sub> fan can differ from the above according to the CO<sub>2</sub> calculation (and diameter of the connected PVC piping).



## 4. PRODUCT DESCRIPTION

### 4.1 Application

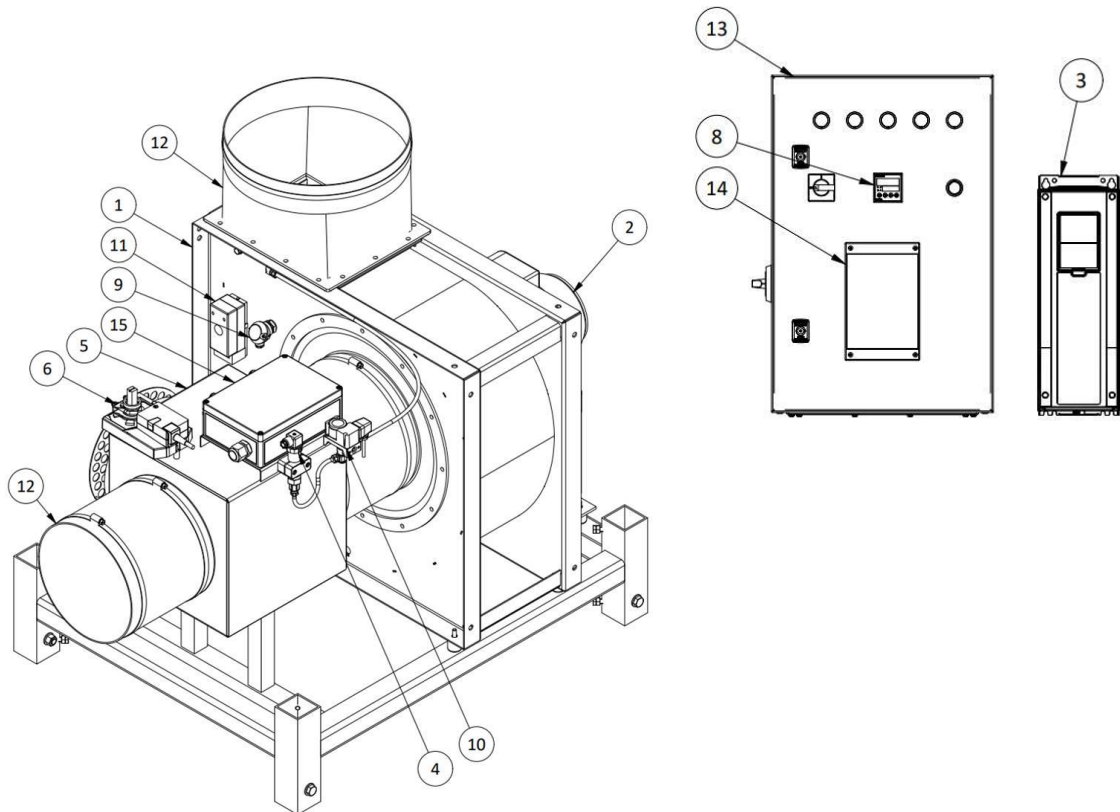

Figure 1 Zantingh CO<sub>2</sub> system

The Zantingh CO<sub>2</sub> fan transports the flue gases to the greenhouse area. The system consists of a stainless-steel fan with a directly linked stainless steel impeller, a three-phase motor and a stainless-steel inlet combination valve. This valve has two openings for flue gas supply and air and is driven by a servomotor. The servomotor can also be provided with an optional temperature controller.

The fan and the inlet combination valve are installed on a robust support frame that has all required temperature and pressure safeties. The piping can be easily connected to the fan by using a flexible connection sleeve on the inlet and outlet sides.

The fan and the inlet combination valve are installed on a robust support frame and has all required temperature and pressure safeties. The piping can be easily connected to the fan by using a flexible connection sleeve on the inlet and outlet sides. The outlet side of the fan can be supplied in various positions, see figure 2 on the next page. This means that it can be used in nearly all circumstances.

The Zantingh CO<sub>2</sub> fan can be easily adjusted with regard to height or it can be connected directly on to a Zantingh flue gas condenser by using the mounting frame and the supplied adjustable supporting legs.

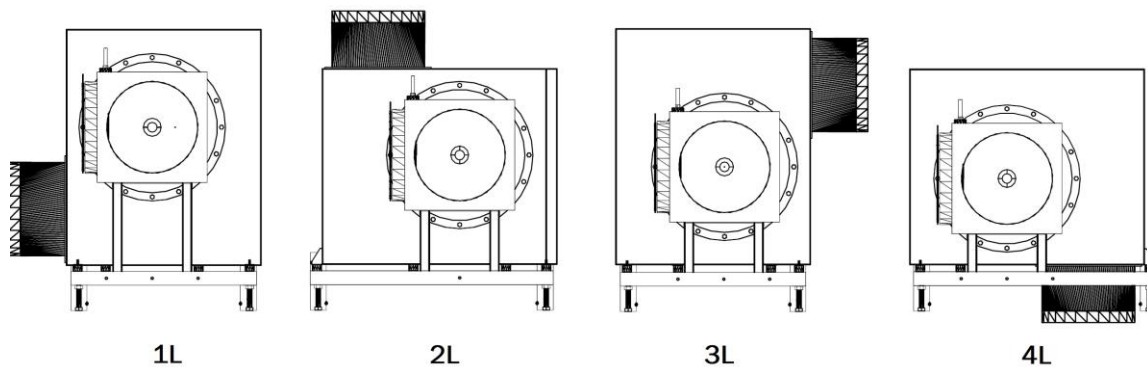

Figure 2 Outlet positions

A switch panel is supplied for the operation of the CO<sub>2</sub> system. The switch panel also has all control and safety equipment and is supplied based on applicable regulations. The panel is equipped, as standard, with star/delta control. The CO<sub>2</sub> fan can optional be equipped with frequency control. It can be used to control the speed of the fan based on the backpressure in the piping. All our switch panels are set up for dosing liquid CO<sub>2</sub> as well.

#### 4.2 System components

The CO<sub>2</sub> system is shipped with the following parts (*please check before installation*):

##### **Assembled as one package before shipment:**

- Stainless steel fan housing and stainless-steel impeller (1).
- Directly coupled AC motor (2).
- Electrical connection box (15).
- Specially constructed, build-on stainless steel inlet combination valve with open/close servo motor (5).
- Pressure sensor to control an optional frequency drive on the fan motor (optional) (4).
- Modulating temperature control (8): when flue gases are too hot and need to be mixed with outside air before entering the greenhouse area (optional).
- A pressure switch for flow monitoring (10).
- Maximum safety thermostat for protection against high temperatures (11).
- A flexible sleeve for the connection of the in and outlet side of the fan (12).
- Mounted together on a specially designed mounting frame with supporting legs (optional).

##### **Separately delivered:**

- Switch panel, with connection for liquid CO<sub>2</sub> dosing (optional) (13).
- Frequency drive for the fan motor (optional) (3).
- CO detector with CO sensor, with or without a sampling pump (optional) (14).

**NB: prior to delivery, the CO<sub>2</sub> system is checked for imbalance of the impeller. A balance certificate is available on request.**

Component description:  
(Refer to figure 1 on page 9)

### **Electro motor (2)**

The motor can be ordered in any voltage according to the country where the system is installed. It is directly linked to the impeller of the fan.

### **Frequency controller (3)**



The frequency drive controls the speed of the fan. It is separately delivered. The matching pressure sensor (4) is installed on the outlet of the CO<sub>2</sub> fan.

See paragraph 5.4 to set up the frequency drive.

Figure 4 Vacon 100 frequency drive and pressure sensor

### **Inlet combination valve (5)**

The inlet combination valve is a three-way valve which has a connection to the chimney or flue gas collector, to the CO<sub>2</sub> fan and outside (mixing) air. It is controlled by an open/close servomotor (6) which is equipped with a limit switch to monitor the valve position. The valve is fully opened to outside (cold) air when the temperature of the flue gasses is too high or when there's no pressure (fan is off). In this position, the valve shuts off the flue gas supply.

Because flue gasses can further condensate while cooling down in the inlet combination valve, a connection (7) for condensate drainage is installed on the valve.

### **Modulating temperature control (8)**



Optionally it is possible to equip the CO<sub>2</sub> unit with a PT1000 temperature sensor (9) which makes the inlet combination valve suitable for modulating temperature control. This makes it possible to dilute the flue gasses with outside air to avoid too high temperatures. The RWF50 controller is visible in the switch panel door. The default setting is 55°C.

See paragraph 5.3 to set up the temperature controller

Figure 5 RWF50 temperature control

### **Pressure switch (10)**

The outlet of the CO<sub>2</sub> fan is equipped with a pressure switch. Only at the set pressure (fan is in operation) the pressure switch becomes active and the inlet combination valve is opened for flue gas supply from the chimney or flue gas collector. This is to prevent flue gasses from entering the boiler room.

### **Thermostat for maximum temperature safety (11)**

A maximum thermostat temperature safety makes sure that the temperature of the flue gas that enters the PVC distribution system never exceeds 60°C. At 60 °C the inlet combination valve is opened for outside air to prevent damage to the PVC piping system and greenhouse plants.

### **Flexible sleeve for in and outlet of the fan (12)**

To easily connect both the inlet and outlet of the CO<sub>2</sub> unit, without tension or vibrations that can damage the equipment, flexible sleeves/cuffs are used. The sleeves are already attached to the unit upon delivery.

### **Switch Panel (13)**

A CO<sub>2</sub> system control panel is delivered unattached. It has either a star/delta circuit (fan is on or off) or a circuit to control a frequency drive (fan can operate at multiple speeds). Every control panel has a possibility to control multiple/combined CO<sub>2</sub> sources, i.e., liquid CO<sub>2</sub> or power engines or -optionally- flue gas valves.

### **CO detector (14)**

The flue gas can contain harmful substances, such as carbon monoxide (CO), which is harmful for humans and plants. When a CO detector is purchased with the CO<sub>2</sub> unit it can be mounted to the CO<sub>2</sub> switch panel; the sensor is installed in the outlet of the fan.

For installation on the chimney Zantingh has model with sample pump available, see figure 6. This model is delivered separately and can be installed separate in the boiler room.

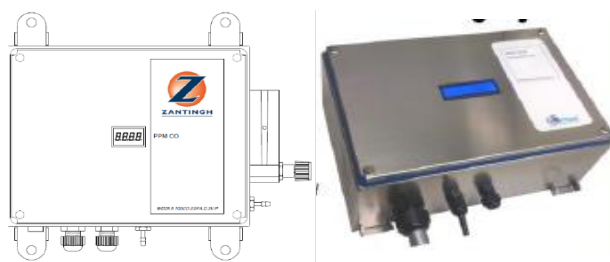

*Figure 6 Zantingh CO detector with pump, see separate manual*

### **Terminal box (15)**

All mounted devices are wired to the terminal box on top of the inlet valve. The fan motor has its own connection.

## 5. INSTALLATION



### IMPORTANT:

Before connecting the system, make sure there are no loose items or animals/pets in the CO<sub>2</sub> fan or inlet combination valve.

- The area around the CO<sub>2</sub> system shall be frost free at all times (also when the equipment is stocked or not in use).
- The CO<sub>2</sub> dosing system shall be accessible from all sides for inspection, service and maintenance. The minimum space required is 0,5 meter.
- The flue gas should not be released into the same area as that from which the combustion air for the CO<sub>2</sub> source is taken.
- The CO<sub>2</sub> dosing system should be installed as close as possible to the flue gas chimney.

### 5.1 Transport and preparations

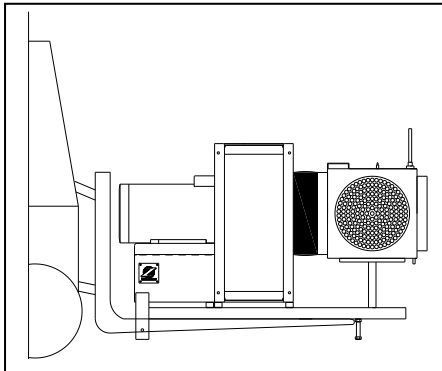

Figure 7 Lifting the CO<sub>2</sub> unit

Only lift the device with a forklift or by using hoisting belts (sling hitches) around and underneath the equipment.



### Minimum Tool Requirement:



Hoisting unit/ forklift  
Drilling machine  
Screw driver  
Measuring rule  
Spirit /water level  
Aluminium tape  
Safety glasses  
Gloves  
Headbox wrench

### Remarks:

- Before beginning the installation, read this manual attentively. When in doubt ask our technical team.
- Keep area clean to prevent accidents.
- Apply nothing but tested and certified hoist- and electrical equipment.

## 5.2 Installation steps

1. Position the CO<sub>2</sub> unit in a way that the inlet combination valve part is directed towards the CO<sub>2</sub> connection on the chimney or (duct to) flue gas collector. If the position of the CO<sub>2</sub> unit is on height, position the unit by means of a forklift or pallet truck. Make sure that the hoisting equipment is suitable for the unit's total weight.
2. Align the inlet of the valve with the CO<sub>2</sub> connection on the chimney/ collector side.



### ATTENTION:

The connecting parts (chimney, condenser, CO<sub>2</sub> connection) may be hot!

3. If you use the Zantingh CO<sub>2</sub> mounting frame, fix the frame to the supplied legs with the supplied bolts.
4. Connect the inlet combination valve to the chimney/ collector or connecting duct using the supplied flexible sleeve (usually already attached to the valve) and matching clamp.
5. When the CO<sub>2</sub> unit is placed directly behind a Zantingh condenser, a special mounting frame is used to fix the unit directly to the condenser. In this case no extra duct is necessary between the connection on the chimney and the inlet combination valve on the CO<sub>2</sub> unit.
6. Connect the outlet side of the CO<sub>2</sub> unit to the PVC piping system using the supplied flexible sleeve and matching clamp.

### IMPORTANT:

Always use the supplied sleeves for the assembly of the CO<sub>2</sub> dosing system. Do not use metal ducts or fix PVC piping directly to the unit. **The connections should be free of vibrations and of tension.**

7. Connect the condensate drain of the inlet combination valve to a siphon by means of a stainless steel or galvanized pipe. **Do not use PVC and do not use a pipe smaller than 2"**. Connect the siphon to the sewer system.
8. All devices (servomotor, maximal thermostat, pressure switch, end switch on inlet combination valve) are pre-wired to the CO<sub>2</sub> terminal box on top of the inlet combination valve. Make the electrical connections to the switch panel using the provided wiring diagram.  
The fan motor has its own connection box.



### IMPORTANT:

The CO<sub>2</sub> dosing system should be connected according to the applicable local standards and regulations.

### 5.3 Configuration of RWF50 modulating temperature control (when applicable)

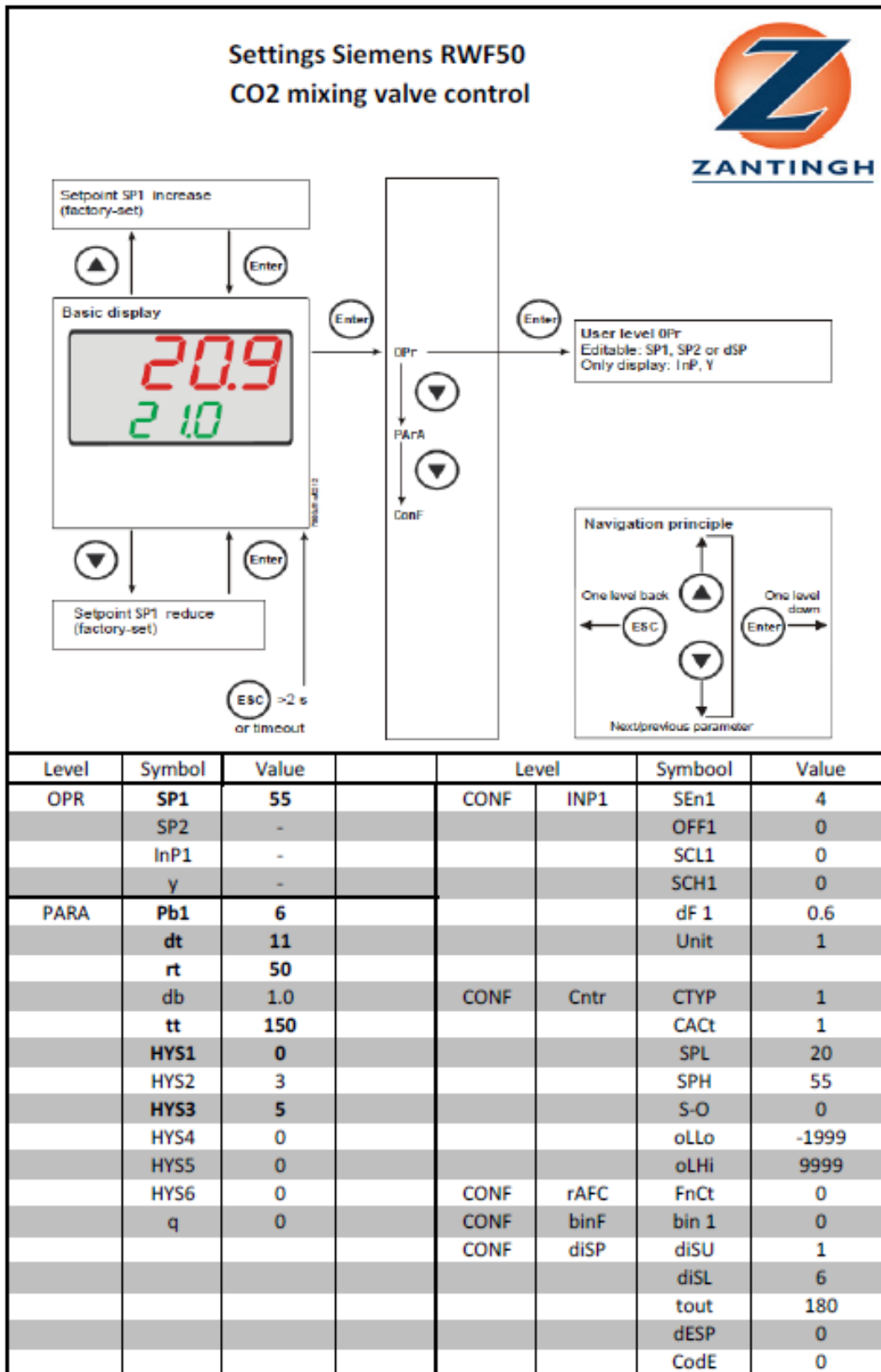

## 5.4 Configuration of Vacon 100 frequency drive (when applicable)

### **Go to Quick menu => Choose Application => PID Control**

Go through the Quick setup menu.

<u>Parameter</u>	<u>Description</u>	<u>Setting</u>
P 3.1.2.2	Motor Type: Induction motor	Induction motor
P3.1.1.1	Motor Nominal Voltage	400V
P3.1.1.2	Motor Nominal Frequency	50 Hz
P3.1.1.3	Motor Nominal Speed	2930
P3.1.1.4	Motor Nominal Current	* see rating plate motor
P3.1.1.5	Motor Cos Phi	* see rating plate motor
P3.3.1.1	Minimum Frequency Reference	15 Hz
P3.3.1.2	Maximum Frequency Reference	50 Hz
P3.4.1.2	Acceleration Time 1	10 s
P3.4.1.3	Deceleration Time 1	10 s
	Make a selection of a control place	I/O
P3.13.1.4	Process Unit Selection	mbar
P3.13.1.5	Process Unit Min	0 mbar
P3.13.1.6	Process Unit Max	250 mbar
P3.13.1.7	Process Unit Decimals	0
P3.13.3.3	Feedback 1 Source Selection	AI2
	signal range of the analogue input	1 = 2/10V / 4-20mA
P3.13.1.8	Error Inversion	Normal
P3.13.2.6	Setpoint Source Selection	Keypad SP1
P3.13.2.1	Keypad SP1	40 mbar *
	Sleep function	No

*Wizard Ready!*

\* The pressure depends on the design pressure resulting from the CO<sub>2</sub> calculation.

Parameters which have to be changed because of the use of digital inputs:

P 1.27	RO1 Function	Fault Invert
P 3.2.3.	KeypadStopButton	0 = No
P 3.5.1.2.	Ctrl Signal 2A	DigIN Slot 0.1
P 3.5.1.11	Ext Fault Close	DigIN SlotA.6
P 3.5.1.13.	Fault Reset Close	DigIN SlotA.3
P 3.5.1.21.	Preset Freq Sel0	DigIN SlotA.2



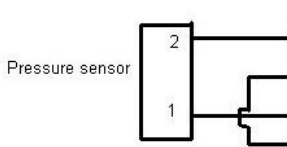

Terminal	Signal	Description
1	+10V <sub>ref</sub>	Reference output Voltage for potentiometer, etc.
2	AI1+	Analogue input, voltage range 0–10V DC. Voltage input frequency reference
3	AI1-	I/O Ground Ground for reference and controls
4	AI2+	Analogue input, current range 0–20mA Current input frequency reference
5	AI2-/GND	
6	+24V	Control voltage output Voltage for switches, etc. max 0.1 A
7	GND	I/O ground Ground for reference and controls
8	DIN1	Start forward (programmable) Contact closed = start forward
9	DIN2	Start reverse (programmable) Contact closed = start reverse
10	DIN3	Multi-step speed selection 1 (programmable) Contact closed = multi-step speed
11	GND	I/O ground Ground for reference and controls
18	AO1+	Output frequency Analogue output Programmable Range 0–20 mA/R, max. 500Ω
19	AO1-	
A	RS 485	Serial bus Differential receiver/transmitter
B	RS 485	Serial bus Differential receiver/transmitter
30	+24V	24V aux. input voltage Control power supply backup
21	RO1	Relay output 1 FAULT Programmable
22	RO1	
23	RO1	

Figure 5 Example of configuration: multicontrol application of pressure sensor

## 6. OPERATION

### 6.1 First start-up



The following procedure is only applicable for a switch panel supplied by Zantingh.

1. Ensure that all ducts, pipes and wires have been correctly connected before putting the CO<sub>2</sub> dosing system into operation.
2. Connection to horticulture computer: set the main switch on the CO<sub>2</sub> panel to “OFF”. Check if there is a signal for CO<sub>2</sub> demand from the horticulture computer, and if it is received by either the burner switch panel or the CO<sub>2</sub> switch panel, depending on the kind of CO<sub>2</sub> system. If there is a CO<sub>2</sub> demand, but the signal is not received, check the wiring diagram for the right terminals.
3. CO<sub>2</sub> supply: if there is a signal for demand; set the main switch on the CO<sub>2</sub> switch panel to “ON”. The CO<sub>2</sub> unit will start and the inlet combination valve will rotate to open the flue gas flow (from chimney/ flue gas collector side).
4. Motor overload signal: measure the current to the electro motor during CO<sub>2</sub> operation of the CO<sub>2</sub> fan. This value is used as the setpoint for the thermal protection. Check the thermal protection by lowering the setpoint to a value below the measured current. A “fan load error” should occur. Check whether the inlet combination valve closes. Then, change the setpoint for the thermal protection to the correct value. Also compare the setpoint with the information on the motor type plate. The setpoint value may not be more than 5% higher than the value on the type plate.
5. Pressure switch: reset the CO<sub>2</sub> system to put it in operation again. Read the pressure at the pressure switch on the outlet of the CO<sub>2</sub> fan. Change the setpoint of the pressure switch to a value 10% lower than the measured pressure. Then increase the setpoint until a “CO<sub>2</sub> transport error” occurs to test if the pressure switch is working correctly. Check if the CO<sub>2</sub> dosing system is switched off and the inlet combination valve is closed. Then set the pressure switch to the correct value.
6. Maximum thermostat: reset the CO<sub>2</sub> system to put it in operation again. IN the max thermostat lower the setpoint for maximum temperature until the “Maximum temperature error” occurs. Check whether the CO<sub>2</sub> dosing system is switched off and the inlet combination valve is closed. Then set the thermostat to the desired value. If PVC piping is used for CO<sub>2</sub> distribution however, **the thermostat setpoint should not exceed 60°C**.
7. Inlet combination valve error: set the main switch on the panel to the OFF position. Manually open the valve to the flue gas. The “Closed position” error should now occur. This may take some time due to time-delay contacts. When this error occurs, the burner system **must** also shut down automatically as a safety procedure.

## 7. MAINTENANCE

Never perform any maintenance or any other activity on the system without adequate knowledge and understanding of the system. When performing any activity on the system, **always switch off the main switch and make sure that it cannot be switched on!**

Maintenance work should be carried at least once a year to ensure that the CO<sub>2</sub> dosing system is functioning correctly and safely. These inspections and maintenance work should be carried out by qualified technicians.



### **IMPORTANT:**

First set the main switch on the burner panel to “OFF” before performing any maintenance work. Lock the switch to ensure nobody can set the main switch to “ON” while performing maintenance. **Never work on the system if the control panel is live (energized).**

Switching off the burner control panel also switches off the power to any connected CO<sub>2</sub> dosing system control panel.

Setting the main switch on the CO<sub>2</sub> panel to “OFF” also switches off the burner. The reset button should be pressed to cancel the error after an error occurs.

### Remarks:

- The equipment is supplied according to the applicable (safety) standards and regulations. However, it is the responsibility of the user to continually warrant the safety by making sure that the system is maintained according to the regulations in force and the professions of this manual.
- To ensure the good operation of the heating system, the boiler room has to be kept clean. It may not be used for storage purposes. The parts which may need maintenance work need to be accessible at all times.
- Keep the air supply grille and air extraction openings free and clean. Inadequate air ventilation can lead to hazardous situations.
- The boiler room has to be illuminated using mounted electrical lighting, to make sure that all parts of the system can be properly maintained even without daylight.
- If you have any doubts concerning the control or operation of the system, please contact your technician or supplier.

### 7.1 Cleaning the equipment

The CO<sub>2</sub> fan interior (impeller) has to be checked for pollution/dust and cleaned thoroughly every year. This work should automatically be carried out by qualified (Zantingh) technicians.

### 7.2 Service term

In optimal operating conditions, a Zantingh CO<sub>2</sub> unit can last up to 20 years. Upon expiry of the service term, it is necessary to carry out a technical diagnosis and, if necessary, an overall repair/revision of the system.

The status is considered to be at its limit if it is technically impossible to continue using it due to noncompliance with safety requirements or a decrease in performance. The owner makes the decision whether to revise and continue using the equipment, or replacing and disposing of it, based on the actual status of the equipment and repair costs.

### 7.3 Seasonal stop

In case of a seasonal stop set the main switch of the CO<sub>2</sub> system switch panel to “OFF”. The power supply to the CO<sub>2</sub> unit will be shut off automatically.

To stop the burner in the seasonal stop, proceed as follows:

1. Turn the burner main switch to “OFF”.
2. Disconnect the main power supply.
3. Close the fuel/gas valve A1 of the supply line.

**Before the start of a new cultivation season, again perform all steps from paragraph 7.1 as if it were a new installation.** Also check the PVC piping system for leaks/damage and the CO<sub>2</sub> tubes/hoses.

Calibrate any CO detector using calibration gas. CO detectors should be **calibrated at least once a year** (the life span of the CO cell is approximately 2 years).

### 7.4 Disposal



#### **IMPORTANT:**

The use of the equipment for other purposes after the expiry of the terms of use is strictly prohibited.

In case of disposal, follow the instructions according to the laws in force in your country about the “Disposal of materials”.

## 8. FAILURE REPORT

Errors are visually indicated by a LED on the switch panel door of the burner system or the CO<sub>2</sub> dosing system. Reset the system by pressing the reset button on the switch panel door. The reset button for the dosing system is located on the switch panel; the reset button for the CO system is located on the CO panel and/or the CO detector

Please contact your local installer or Zantingh service department when an error occurs that cannot be resolved

### 8.1 Troubleshooting



#### IMPORTANT:

**Switch off the main switch on the CO<sub>2</sub> panel before performing any service activities. Ensure it cannot be switched on during the activities. Never perform any work on the system if the power is on.**

Setting the main switch on the CO<sub>2</sub> panel to "OFF" also switches off the burner. The reset button should be pressed to cancel the error after an error occurs.

Error	Possible Cause	Possible Solution
Burner error	Main switch on CO <sub>2</sub> panel is switched off.	Switch it on.
	Inlet combination valve is not closed.	Close the valve.
Transport error	The descending pipe is broken.	Repair the pipe.
	Transition timer setting is too low.	Increase the value of the setting.
	CO <sub>2</sub> dosing fan rotates in the wrong direction.	Check the direction of rotation and adjust it.
	Pressure switch is set incorrectly.	Measure the pressure and reset the setting for the pressure switch.
	Pressure switch is defective.	Replace it.
Max. temp(Maximum temperature)	Condenser cooling is insufficient.	Check the for pollution at the water and/or flue gas side.
	The amount of air that is mixed is not enough.	Set the inlet combination valve to mix in more air.
	Thermostat is defective.	Replace it.
	Thermostat setting is too low.	Increase the setting. The value should be < 60°C.
Thermal disconnection	No tension/voltage (three-phase).	Check the fuses.
	Thermal protection is defective.	Replace it.
	Motor bearings are defective.	Replace the bearings.
	Fan is polluted or imbalanced.	Clean it.
Closed position	Servomotor is defective.	Replace it.
	Limit switch is defective.	Replace it.
	Transition timer setting is too low.	Increase the value of the setting.
CO error	Burner burning has changed.	The burner should be checked.
	CO sensor is not working properly.	Calibrate the sensor.

## **9. WARRANTY CONDITIONS**

Zantingh B.V. guarantees this Zantingh product for the installer under the following conditions. The installer guarantees this product to the user under the same conditions provided below.

1. The period of guarantee is valid as from the day of delivery on location. The guarantee has a fixed period of 12 months, based on the agreed sales price.
2. The device should be installed by a recognized installer according to the applicable general and local standards and regulations and the assembly and operation instructions provided by Zantingh.
3. The system may not be moved from the original location.
4. The guarantee becomes null and void if and when:
  - Defects of the system are not reported in writing to the installer and/or Zantingh B.V. immediately after having been discovered or these could have been discovered.
  - Defects are caused by errors, improper use or neglect by the user and/or installer who has given the order or his/her legal successor or caused by external causes.
  - During the period of guarantee a third party is requested to or make provisions to the system or when the user has done so without prior written consent by the installer and/or Zantingh B.V.
  - During the period of guarantee no expert inspections and/or maintenance work are periodically performed to equipment requiring the same.
  - Corrosion has been caused by polluted flue gas, to be determined by Zantingh B.V.
  - If after research is carried out, one or more of the above conditions have not been taken into account and are the reason for any guarantee claim, the costs for the required research by Zantingh B.V. or third parties will be charged to the user.
5. The initial request based on the guarantee obligations described in this article should be submitted in writing to the installer within five working days after the error or defect has been observed or could reasonably have been observed.
6. The stipulations included in our general guarantee, sales and payment conditions, issued by the ORGALIME S 2000 “General conditions for the supply of mechanical, electrical and electronic products” are also applicable. Zantingh B.V. will not be liable for any consequential damage to the Zantingh system other than a defect covered by the guarantee as described above. Moreover, Zantingh B.V. will not be liable for any damage to income and/or loss of profit to the user of any nature what so ever.
7. Any costs incurred by assembly or disassembly, travelling or accommodation expenses, constructional costs and such required to execute the terms of the guarantee are excluded.

Any dispute between Zantingh B.V. and the buyer regarding a claim based on the guarantee, will be resolved by an expert and independent authority if so desired. The parties agree to abide by the binding decision of said authority.

## **Imprint**

All rights reserved, including the rights to the translations. Nothing from this issue may be copied, stored in an automatic data file or made public in any way or by any means, be it electronically, mechanically, photocopy or otherwise, without prior written consent from Zantingh B.V. Reprinting, including excerpts, is forbidden. Changes, errors and misprints reserved. These assembly and operation instructions comply with the technical requirements at the time of printing. We reserve the right to make technical and design changes.

## **Netherlands**

### **Zantingh B.V.**

Aarbergerweg 9, 1435 CA Rijsenhout  
Postbus 255, 1430 AG Aalsmeer  
The Netherlands  
Phone (+31) (0)297 - 219 100  
E-mail [info@zantingh.com](mailto:info@zantingh.com)  
Website [www.zantingh.com](http://www.zantingh.com)

## **France**

### **Zantingh France SARL**

95, rue F. de Lesseps  
F-44150 Ancenis  
France  
Phone (+33) (0)240 83 94 30  
E-mail [info@zantingh.fr](mailto:info@zantingh.fr)  
Website [www.zantingh.com](http://www.zantingh.com)

## **Mexico**

### **Zantingh México S.A. de C.V.**

Parque Industrial Benito Juárez  
Acceso III no.14  
76120 Querétaro  
Mexico  
Phone (+52) 422 209 50 60  
E-Mail [info@zantingh.mx](mailto:info@zantingh.mx)  
Website [www.zantingh.com](http://www.zantingh.com)