

Aarbergerweg 9  
Rijsenhout  
P.O. Box 255  
1430 AG Aalsmeer (NL)  
Tel. +31 (0)297 219 100  
Fax +31 (0)297 219 199  
www.zantingh.com

## OPERATING INSTRUCTIONS

### ZANTINGH CO DETECTOR MODEL ZCO-WD22.100

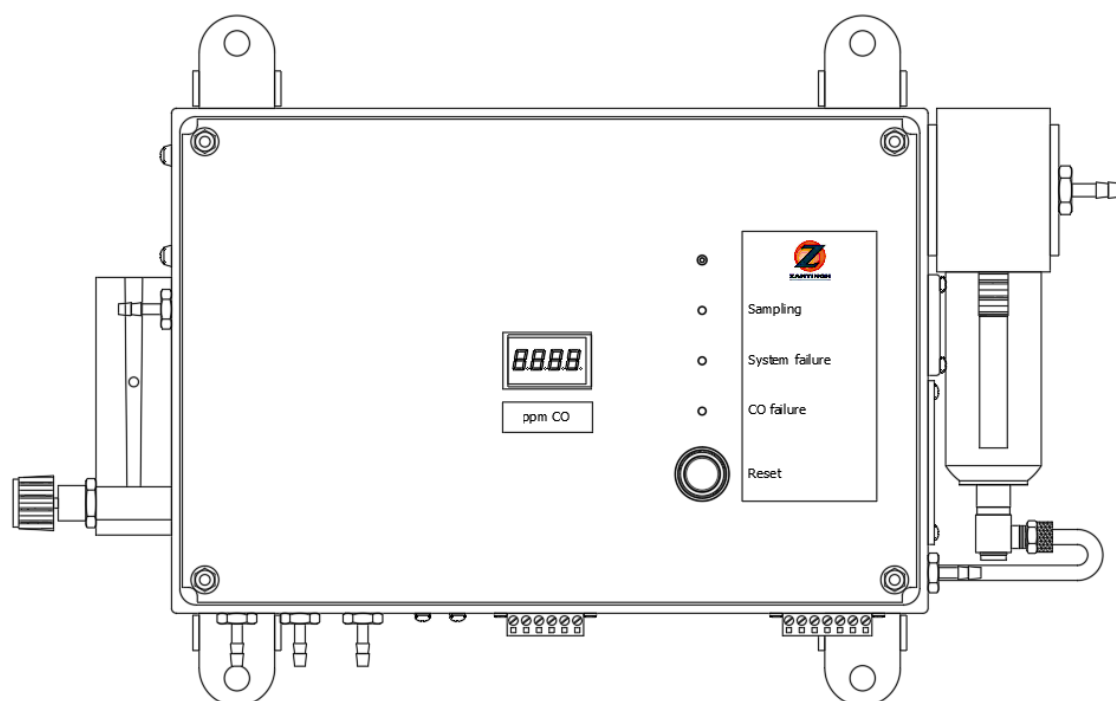

ABN AMRO 49.42.46.294  
BIC ABNANL2A  
IBAN NL17ABNA0494246294  
KvK. A'dam 34041535  
BTW nr. NL0015.13.138.B.01

The FME-CWM terms and conditions (the FME(-CWM) is the Dutch employers' organisation in the technology industry) are applicable to all our deliveries and services to (contract) parties in the Netherlands. (These terms and conditions are registered in Dutch at the Chamber of Commerce in The Hague, The Netherlands.) The Orgalime S 2000 General conditions (Orgalime is the European Engineering Industries Association) are applicable to all our deliveries and services to (contract) parties outside the Netherlands. (These terms and conditions are registered in Dutch at the Chamber of Commerce in Brussels, Belgium.)



## **IMPORTANT read this first!**

The operating instructions are an integral part of the product.

The instructions contain important information on the assembly, commissioning, usage and operation of the product. Please read the assembly and operating instructions carefully.

The guarantee becomes null and void if the assembly and operating instructions are not followed. Zantingh B.V. cannot be held liable for these damages.

Store this manual carefully near the system!

### Table of content:

page

<b>1. INLEIDING</b>	<b>3</b>
<b>2. UITLEG EN WERKING VAN DE CO-DETECTOR</b>	<b>4</b>
<b>3. INSTALLATIE VAN DE CO-DETECTOR</b>	<b>5</b>
3.2 Aansluiten van de slang	6
3.3 Ingebruikname	9
3.3.1 Aansluiten van de voedingsspanning	9
3.3.2 Aansluiten van de relaisuitgangen	9
3.3.3 Aansluiting en functionaliteit van het start signaal	11
3.3.4 Aansluiting en functionaliteit van het reset signaal	11
3.3.5 Aansluiting van het 4-20mA uitgangssignaal	12
3.4 Kalibreren van de sensor	12
3.5 Inregelen van het schakelpunt van het alarmrelais	14
<b>4. FUNCTIONALITEIT DISPLAY EN LED'S</b>	<b>16</b>
<b>5. DE AUTOMATISCHE SPOELFUNCTIE</b>	<b>17</b>
<b>6. INSTELLING BY-PASS REGELING</b>	<b>18</b>
<b>7. KRUISGEVOELIGHEID VAN DE SENSOR</b>	<b>19</b>
<b>8. ONDERHOUD VAN DE CO-DETECTOR</b>	<b>20</b>
8.1 Vervangen van het filterelement	20
<b>9. SPARE PARTS</b>	<b>21</b>
<b>10.GARANTIEVOORWAARDEN</b>	<b>20</b>

## **1. INTRODUCTION**

Dear Customer,

We would like to thank you for purchasing our product.

Please read the assembly and operating instructions carefully before installing the CO detector. The safety and operating instructions must be followed.

Our technical department can provide additional information and support. If you have any questions, please contact us:

<b>Telephone (reception)</b>	<b>+31 (0)297 219 100</b>
<b>Telephone (service department)</b>	<b>+31 (0)297 219 125</b>
<b>Telephone (repair services)</b>	<b>+31 (0)20 48 58 212</b>

Or by mail:

[info@zantingh.com](mailto:info@zantingh.com)

## **2. INFORMATION ON AND OPERATION OF THE CO DETECTOR**

The ZCO-WD22.100CO is a stationary CO detector with an advanced, integrated gas conditioning system for optimum measurement results.

After an external start signal, the sample gas will be guided through the input filter with the help of an integrated pump. This input filter is located on the exterior of the housing. Any condensate is separated in the filter and automatically discharged by means of an integrated peristaltic pump that is set to periodically drain the accumulated moisture.

The integrated Peltier gas cooler ensures the temperature of the sample gas is decreased and the moisture content of the gas is reduced to a minimum. The released condensate is automatically discharged using a second integrated peristaltic pump.

The heated housing includes a thermostat, to provide a consistent temperature where condensate does not form which in turn guarantees optimum accuracy of measurement.

The electronics ensure periodic purging of the sensor with ambient air, to ensure there is no drift from the zero point of the measurement signal. The CO detector will generate an alarm when the gas concentration exceeds the set value based on a configured setpoint. This causes a relay to be automatically released. External equipment can be connected to the relay using a connector on the exterior of the device. When the gas concentration reaches a measured value that is well above the alarm limit, the CO detector will automatically purge with ambient air to protect the sensor.

In the event of failure, the CO detector releases a relay, switching any external actuator(s) on or off.

When the CO detector enters an alarm mode because the gas concentration exceeds the alarm limit, it will remain in operation at all times but switches to the purging operation. A reset signal is required for the CO detector to return to measuring gas samples (only when the temperature in the housing is sufficiently high).

### 3. CO DETECTOR INSTALLATION

#### 3.1 Mounting

The housing is equipped with 4 mounting brackets that can be used to easily mount the device on a solid wall. It is beneficial to the lifespan and measuring accuracy of the system when the wall is free of vibrations, moisture, heat or freezing temperatures. The mounting brackets are bolted at the rear by means of bolts with a hexagonal head which may be removed if required.

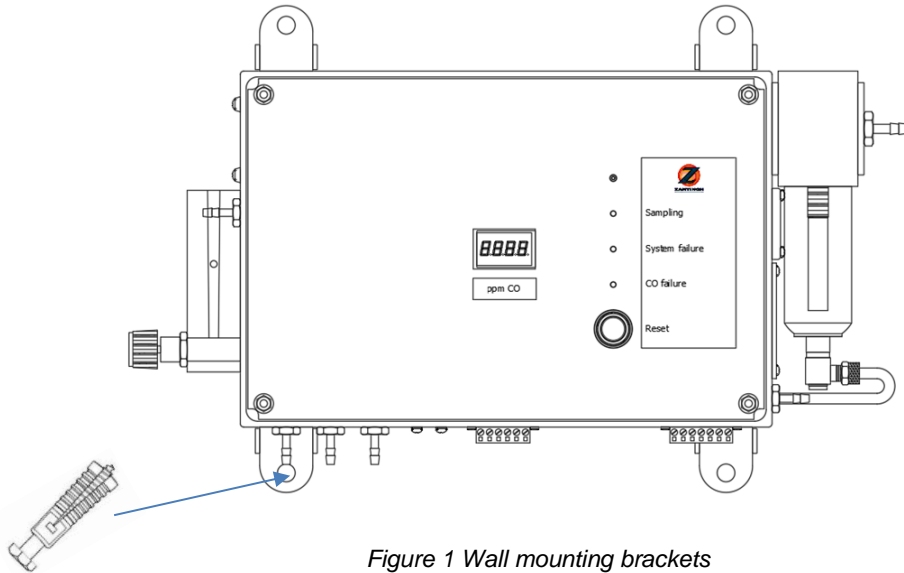

Figure 1 Wall mounting brackets

Mount the housing using a level and ensure the lid is properly mounted at all times, without any gaps. Improper mounting will result in poor measurement results and defects caused by moisture (condensate drainage). Never suspend the detector from a condenser.

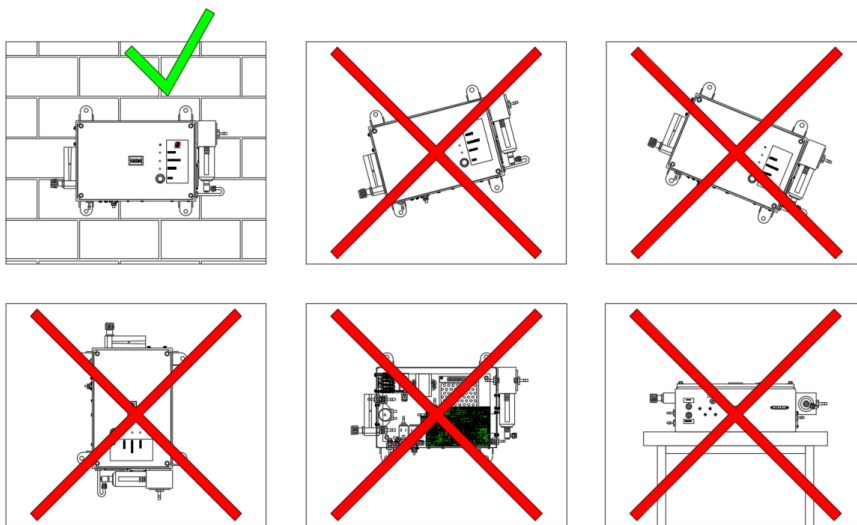

Figure 2, Correct and incorrect mounting

### 3.2 Connecting the tubes

It is recommended to use  $\varnothing$  ID 4 mm/ $\varnothing$  OD 6 mm tubing for the various connections on the CO detector, as shown below:

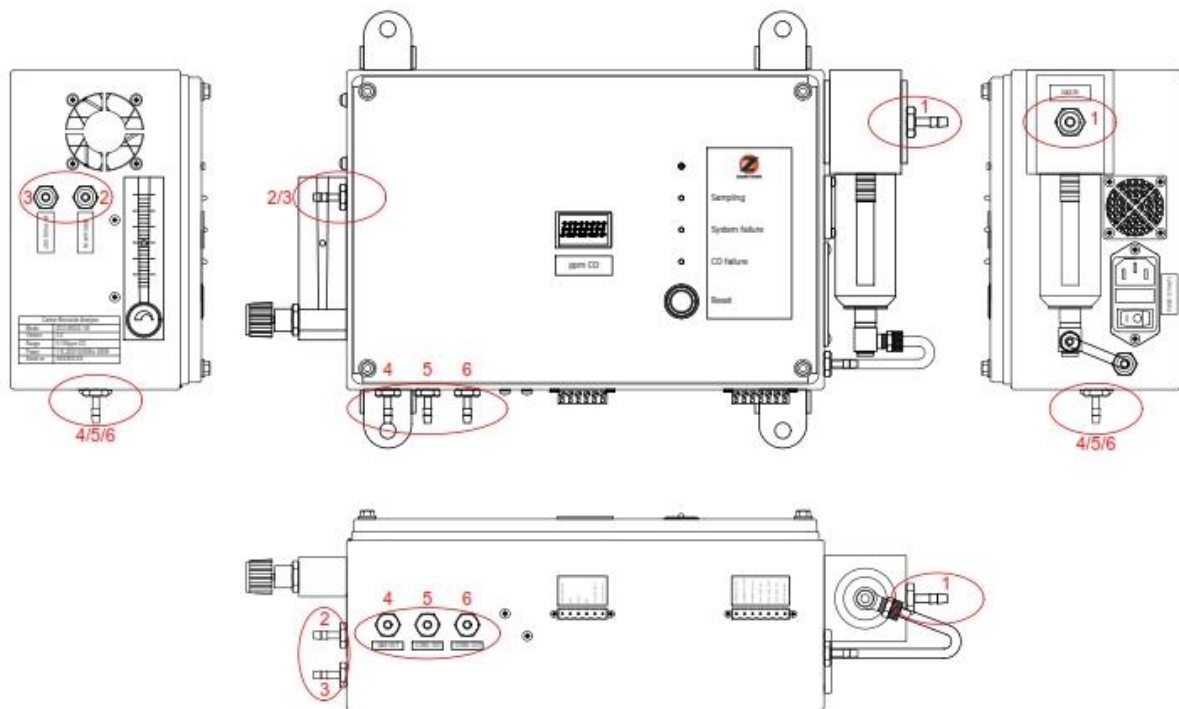

Figure 3 Various hose connections

For easy connection, the CO detector is equipped with hose bars to which a hose with an internal diameter of 4 mm can be attached.

- 1. Gas sampling connection.
- 2/3. Calibration and bypass connection; must always be accessible.
- 4/5/6. Condensate discharge and sample gas; must always be accessible.

The CO detector includes a connection kit for the gas sampling point:

- 10 metres DN04/06 PTFE tube, UV resistant (-196 °C to +260 °C)
- One straight G1/2"/DN06 connector
- One DN06/DN06 angled connector
- One metal connector

Connect the connectors as indicated below:

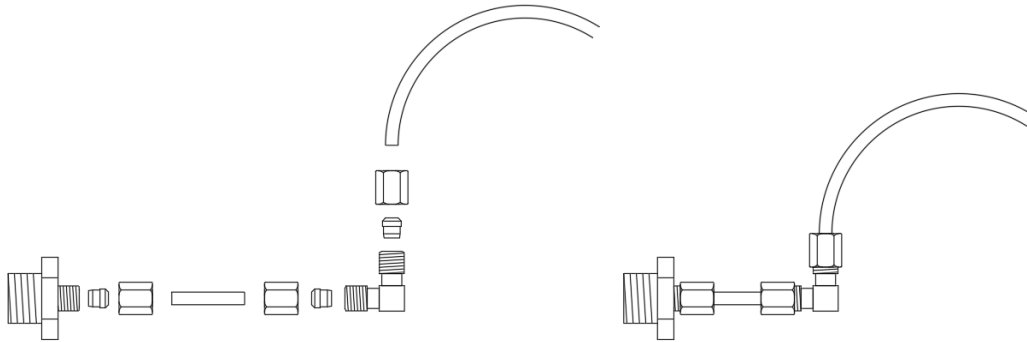

Figure 4, Angled connector

Tighten the connectors to make sure no leaks occur. The connector nuts have to be turned  $1\frac{1}{4}$  to  $1\frac{1}{2}$  turns. The compression ring must be positioned as indicated in the diagram.

Make sure that the angled connector always points upwards to ensure the hose first goes upwards. Any condensate can flow back to the sampling point this way.

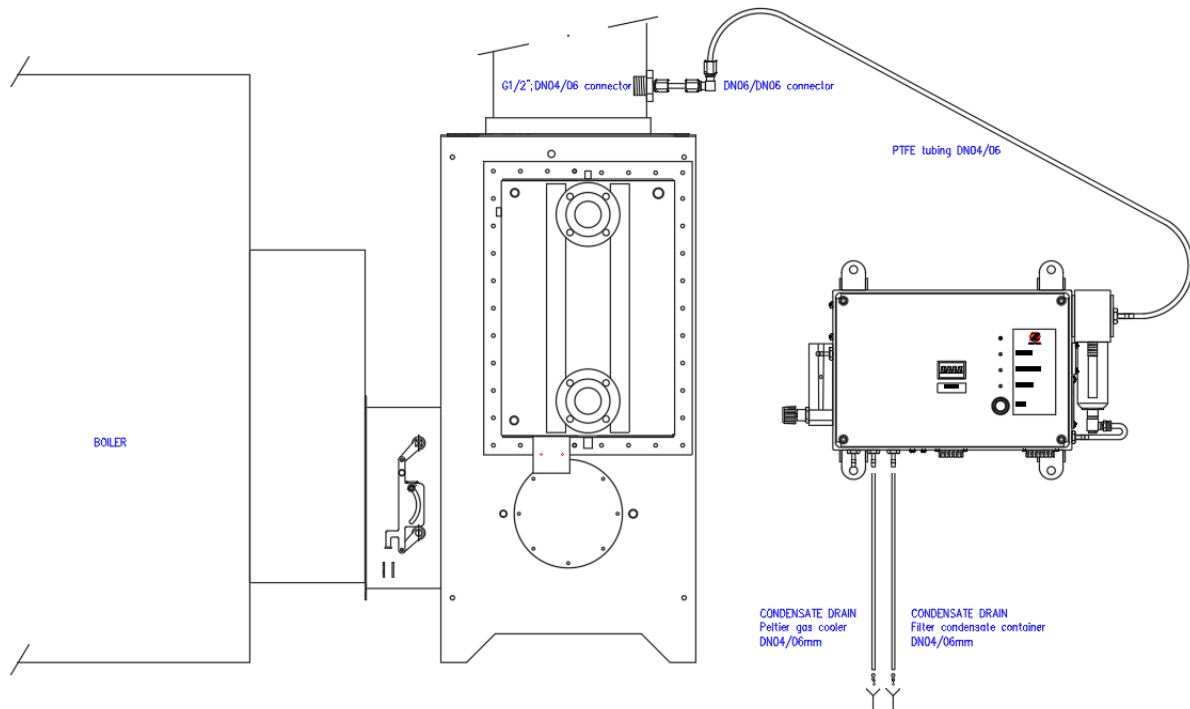

Figure 5, Connecting the test and measurement hose

Should you not use the connection kit, please make sure that the hose is no more than 30 metres long (from sampling point to the detector) and that the diameter is less than 6 mm. A sampling hose with a smaller diameter and a shorter length has a positive effect on measurement response time.

An additional sampling point is recommended should a longer hose length be required, as shown below.

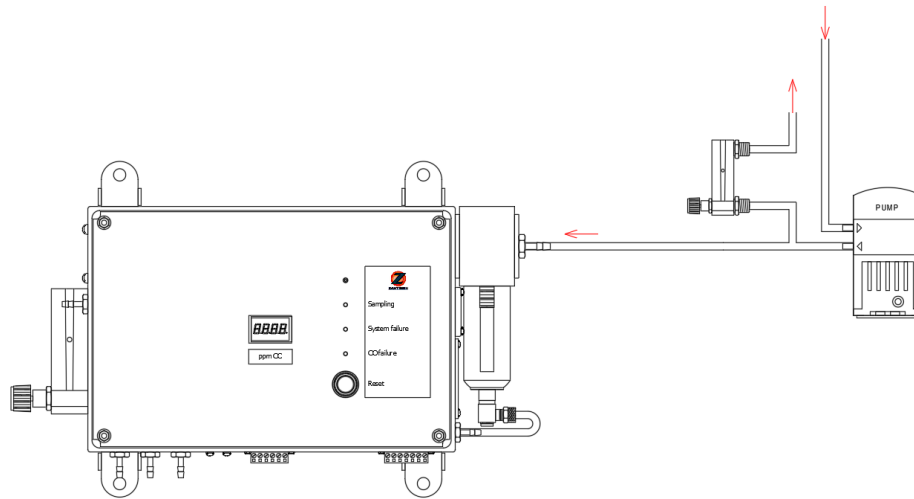

Figure 6, Connecting the bypass

Prevent that a water seal is formed (water trap effect) as indicated below.

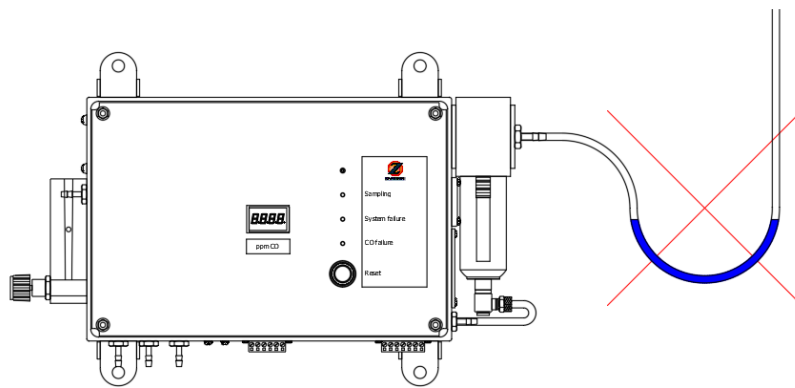

Figure 7, Water trap effect

Try to limit the length of the sampling hose but never mount the CO detector near a flue or on the condenser because of the high temperatures! We recommend mounting the CO detector in an area where the temperature is between +5 °C and +40 °C.



### 3.3 Commissioning

#### 3.3.1 Connecting the supply voltage

The CO detector comes with a separate C13 device plug, a cable with a country-specific contact plug can be attached to this device plug. The system can be connected to a 115 V/60 Hz or a 230 V/50 Hz power supply. Attention: The CO detector should always be in operation to prevent the forming of condensation (in the CO detector). Never switch off the CO detector. Keeping the CO detector in operation has the advantage that condensation flowing from the sampling hose will always continue to be discharged by the pump.

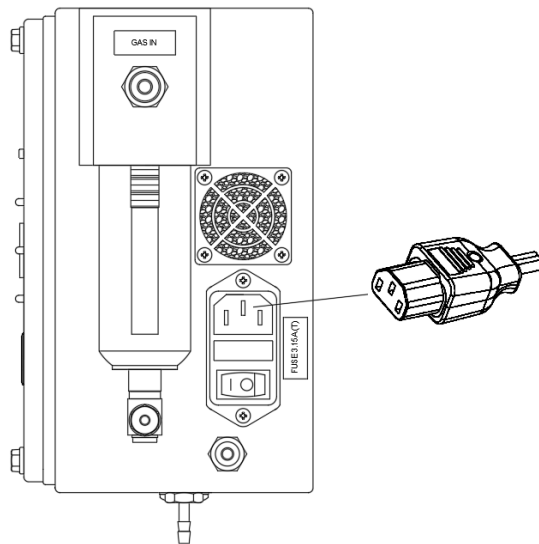

Figure 8, C13 connector

#### 3.3.2 Connecting the relay outputs

The CO detector has two relay outputs:

1. An SPDT "Fault" relay output for fault status. This relay is released when a fault occurs.
2. An SPDT "Alarm" relay output for when the set limit value for the gas concentration is exceeded.

There are several reasons why a fault may cause the fault status relay ("FAULT") to release:

- CO detector is too cold (problem with heating).
- Flow error (clogging in the sample line or a problem with the pump).

In the event of a fault, the fault relay is released (= no power supply), the display is dark (no characters) and the mA output switches to:

- 1.5 mA in case of a heating problem (CO detector too cold).
- 0.5 mA in case of a problem with the flow.

In case of a heating problem, the CO detector will also switch to the purging function in order to prevent damage caused by condensation.

The alarm relay is released when the CO concentration exceeds the set value. The following criteria is applied:

1. CO more than 1 minute between setpoint value (factory setting 30 ppm) and 70 ppm.
2. Immediately if the CO value exceeds 70 ppm.

Simultaneously with the release of the alarm relay, the CO detector will switch to the purge function to protect the sensor against high concentrations of CO. The alarm relay will maintain the alarm status (no power supply) until a reset pulse is emitted.

The CO detector comes with a 7-pole plug for the two relays to which various connections can be attached. The figure below shows how the connector is to be assembled.

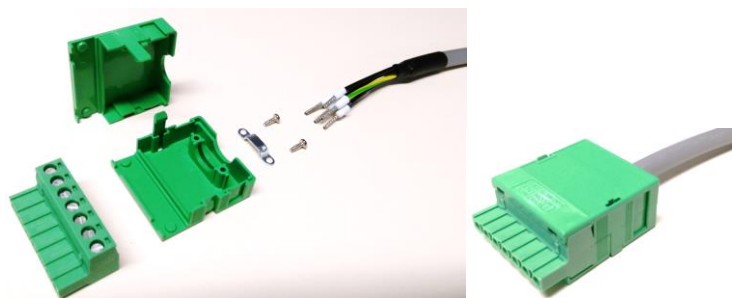

Figure 9, 7-pole connector assembly

The connections for the two relays in the 7-pole connector are as follows:

- Pole 1: Alarm relay NO (Normally Open)
- Pole 2: Alarm relay COM
- Pole 3: Alarm relay NC (Normally Closed)
- Pole 4: Fault relay NO (Normally Open)
- Pole 5: Fault relay COM
- Pole 6: Fault relay NC (Normally Closed)
- Pole 7: PE (Protective Earth)

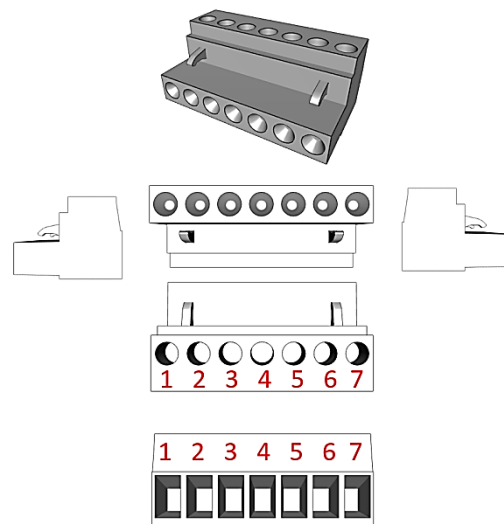

Figure 10, 7-pole cable connector options

### 3.3.3 Connection and functionality of the start signal

The CO detector can be activated by means of the start signal (physical switch or relay). The CO detector is in operation at all times, but purges the sensor with air until START is activated. Once the system is activated it starts measuring the CO content of the flue gases. Refer to figure 11 for the connections required for the start signal.

**ATTENTION:** The system only measures the CO content when it receives a START signal. If the start signal is deactivated, the CO detector switches to purging mode.

Pole 1: START sampling  
Pole 2: GND  
Pole 3: RESET  
Pole 4: GND  
Pole 5: -mA signal  
Pole 6: +mA signal

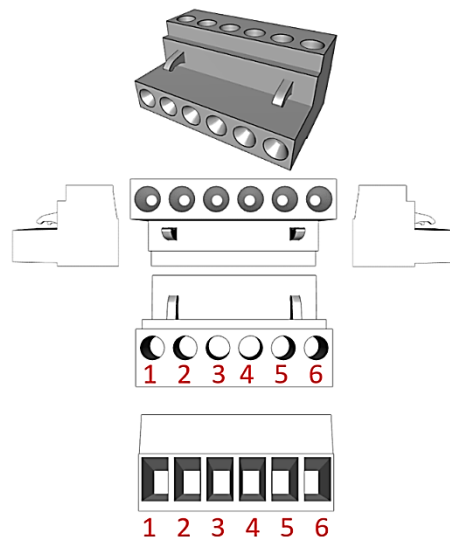

Figure 11, 6-pole cable connector options

### 3.3.4 Connection and functionality of the reset signal

When the CO detector is in a fault mode due to a malfunction, the fault status relay is released. Possible causes of malfunctions are:

- Saturated sample filter.
- Sample gas supplied under negative pressure.
- Obstruction in the measuring pipe.
- Defective or worn sampling pump.
- Electronic malfunction (e.g. relay).
- Malfunction of the integrated heating system and/or the heating setpoint is not reached.
- Malfunction of the integrated 3-way purge valve.

If the fault is caused by a temperature, flow or other issue, the fault will probably reoccur and the cause must be addressed immediately.

After a RESET, either via the button on the housing or externally (by means of a switch or relay), the fault relay is reset. If START is active, the CO detector also switches to measuring gas samples.

The connections for START and RESET in the 6-pole connector are indicated in figure 11.

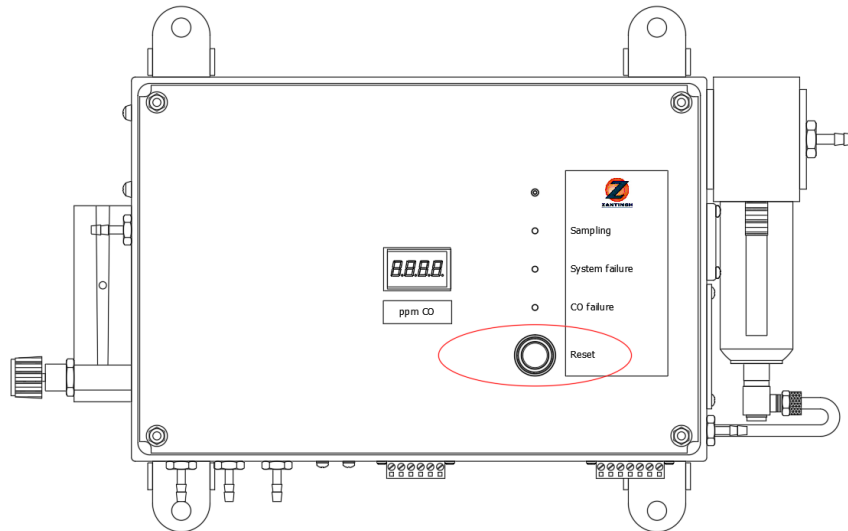

Figure 12, Reset switch

### 3.3.5 Connection of the 4-20 mA output signal

The 6-pole connector can also be used to connect the 4-20 mA signal, using a galvanic insulated connection. In order to identify potential faults quickly, the mA signal distinguishes between a potential causes:

- 2.5 mA: fault caused by a high CO value (display indicates “oLL”).
- 1.5 mA: fault caused by temperature issue (display does not indicate a value).
- 0.5 mA: fault caused by flow issue (display does not indicate a value).
- 0 mA: fault caused by hardware issue (electronics issue) (display does not indicate a value).

### 3.4 Calibrating the sensor

The CO detector can be calibrated as follows:

1. Return the CO detector to your dealer for periodic inspection and calibration.
2. In-house inspection and calibration of the CO detector by qualified personnel.

Every version has two potentiometers that allow the configuration of the zero and span. The use of calibration gas with a relative accuracy of at least  $\pm 2\%$  in order to guarantee optimum operation is recommended.

The use of a high-quality pressure regulator is essential for proper calibration. The gas has to reach the sensor at the right flow and without fluctuations.

Make sure the CO detector is connected and at operating temperature before starting the calibration. When a new electrochemical sensor is installed, a stabilisation period of at least 3 hours must be observed, after which the sensor is ready for use.

The zero must always be calibrated first. Use 100% Nitrogen (N<sub>2</sub>) for this.

Always use a flowmeter with needle valve during the calibration as indicated below:

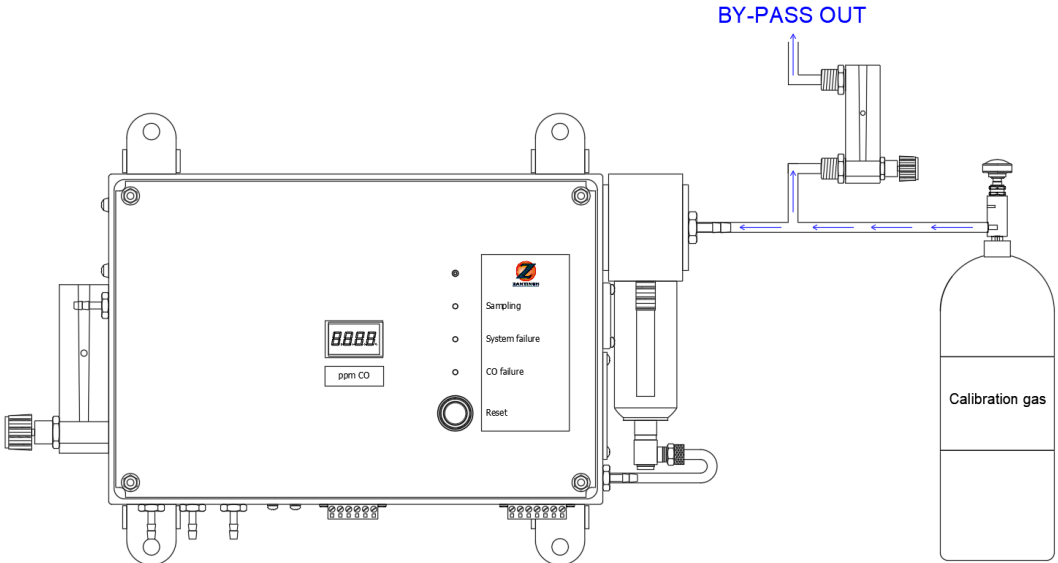

Figure 13, Calibration with calibration gas using a bypass

The flowmeter can be used to verify whether an actual positive flow (= very slight overpressure) is supplied to the CO detector. This bypass flow should only be marginally higher than the flow to the CO detector. The zero can be calibrated based on the display information on the front panel or on the 4-20 mA output on the 6-pole connector (figure 11). 100% N2 = 4.00 mA applies to all models.

The zero calibration can be easily performed using the zero potentiometer on the circuit board in the housing (figure 14).

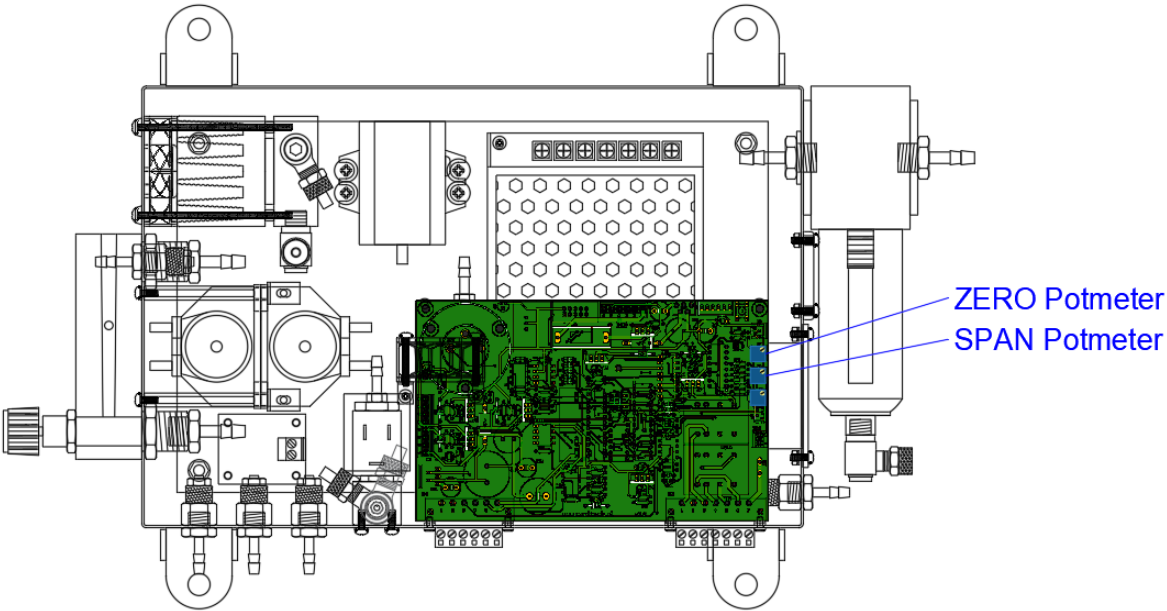

Figure 14, Zero and span potentiometers

Next, the span calibration can be carried out, provided that the zero calibration has been successful.

For the span calibration, it is recommended to use calibration gas with a relative accuracy of  $\pm 2\%$ . The gas concentration can be selected freely, although it must remain below the setpoint value (factory setting 30 ppm) to prevent activation of the purge function.

Using a calibration gas that with several components is not recommended based on cross-sensitivity of the sensor.

Supply the calibration gas to the sensor for a sufficient period of time until the measuring value on the mA meter does not (significantly) change, i.e. is stable. The time required depends greatly on the type of sensor, the condition of the sensor, the ambient temperature and the selected concentration.

The sensor can be adjusted using the span potentiometer. If the adjustment compared to the previous calibration is significant and/or the sensor response is slow when reacting to the calibration gas, replace the sensor. Contact the dealer to order a replacement part.

### 3.5 Adjusting the release value for the alarm relay

The standard factory setting for the alarm limit is 30 ppm CO. When this value is reached, the alarm relay is released. This alarm limit can be seamlessly configured to a lower or higher threshold value using a potentiometer.

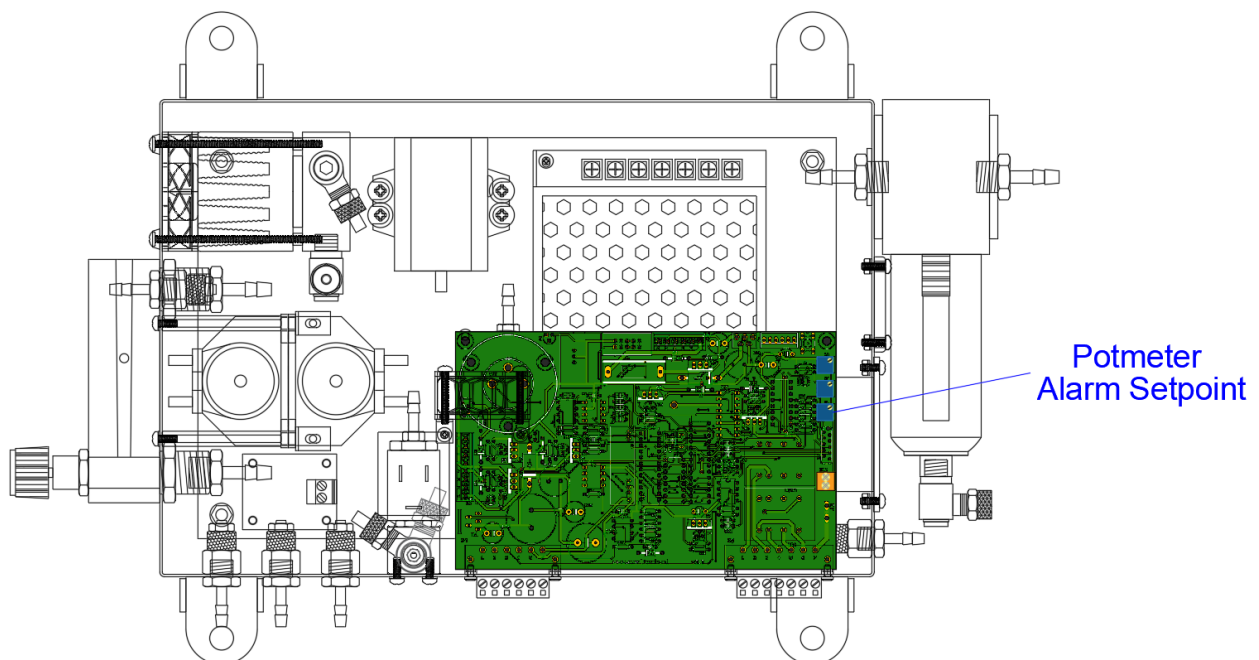

Figure 15, Potentiometer for the alarm limit for the CO measurement value

The 2-pole connector makes it easy to connect a multimeter. The following connection options apply:

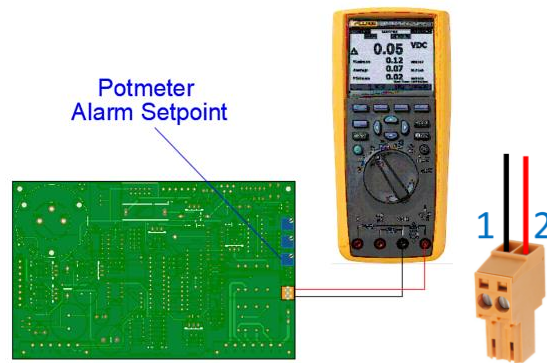

Figure 16, Configuring the alarm level

- Pole 1: GND
- Pole 2: Reference voltage for CO alarm limit value (0-5 volts)

The voltage can be seamlessly configured to a value between 0 and 5 volts using a potentiometer:

0 volts = 4 mA = 0 ppm CO

5 volt = 20 mA = 100 ppm CO (full measuring range of the CO detector)

Formula:  $(\frac{\text{alarm limit}}{\text{sensor measuring range}}) \times 5 \text{ volts} = \text{reference voltage}$

Example: For an alarm limit of 35 ppm CO the corresponding reference voltage according to the formula is as follows:

$$(35/100) \times 5 = 1.75 \text{ volts}$$

In case of a measurement value of  $\geq 70$  ppm CO, the CO detector will automatically start to purge with ambient air. An alarm setting of  $\geq 70$  ppm CO has no added value.

#### 4. FUNCTIONALITY DISPLAY AND LEDS

The following applies to versions with integrated illuminated display:

- The display has 4 digits.
- The indication on the display follows the mA signal.
- The value on the display is the current measurement value of the CO gas concentration in ppm.

The display shows an error message when the mA signal reaches a certain upper or lower limit:

Display message: “oLL” = mA signal is  $\leq 3$  mA



Figure 17, Display with measurement value in ppm of CO

The display is part of the 4-20 mA current loop, it will, therefore, not function if the mA output is not connected to the connector. If the mA output is not in use, the loop must be closed for the display to function (connect poles 5 and 6 in the connector as shown in figure 11).

The cover includes three bicolour LEDs to indicate the following status options:

LED name	RED	GREEN
Sampling	- CO concentration is too high, OR - A system fault, OR - Start is not activated.	- System is measuring.
System failure	- Too little or no flow, OR - Internal temperature too low.	- Flow and temperature are appropriate.
CO failure	- CO concentration is too high.	- CO concentration within programmed limits.

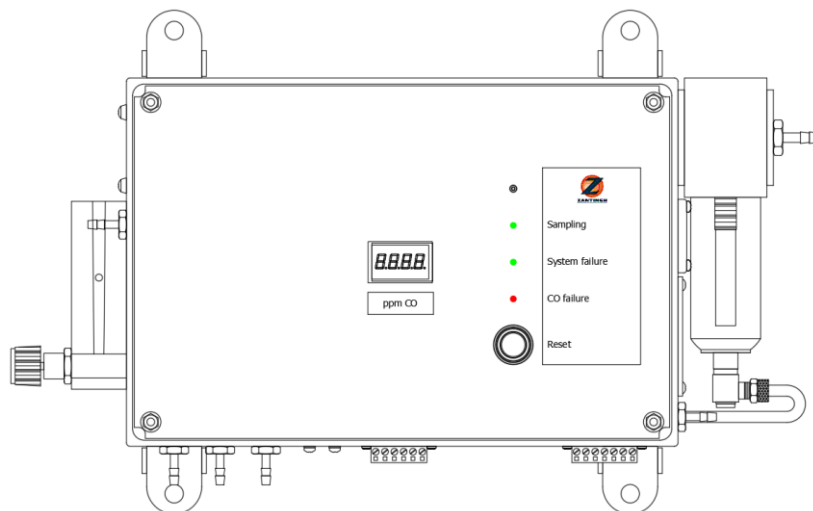

Figure 18, Status LEDs on front panel



## 5. AUTOMATIC PURGE FUNCTION

The CO detector is equipped with a 3-way purge valve. This valve ensures that the flow of the sample gas to the sensor is periodically interrupted switching to outside or ambient air.

This functionality has a positive effect on the sensor and the measurement signal:

- Periodically purging the sensor with a dry gas (e.g. ambient air) allows it to dry. A damp sensor will not provide representative measurements and/or may the response may be slow.
- Stability of the zero is especially important when measuring low concentrations.
- Purging the sensor with a zero gas (ambient air) forces the sensor to return to a zero value. This prevents the sensor from becoming sluggish as a result of saturation with higher gas concentrations.

The CO detector will purge with air for 2 minutes once every 60 minutes. During this process, the display will indicate the last measured value. This also applies to the mA signal. A small fluctuation in the measurement signal may occur when the CO detector switches back to measuring CO.

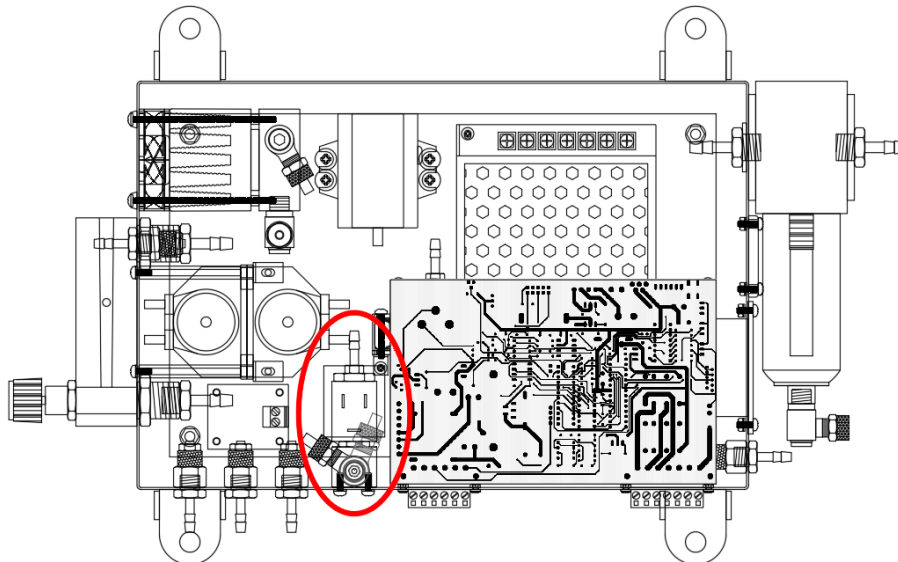

Figure 19, 3-way purge valve

Attention: **No CO should be present** when purging with ambient air! For example, CO from:

- Smoking.
- Combustion engines (forklift trucks, cars, trucks and other engines).

When a measurement value of 0 ppm CO cannot be guaranteed within the room, place a tube to the exterior of the building. Take the maximum length of 30 metres of tube into account. An external pump with bypass must be used if more than 30 metres are required.

Alternatively, a calibration gas cylinder with 100% N<sub>2</sub> or synthetic air, combined with a demand flow pressure regulator can also be used.

## 6. BYPASS SETTINGS

The integrated pump provides the right amount of flow for the sensor. Any excess flow is removed from the sensor area via the bypass. The CO detector includes an external flowmeter with needle valve for the bypass. During normal operation, the flowmeter ball indicates between 0.3 and 0.8 litre/min. The needle valve is completely open by default (control knob on the flowmeter turned as far as possible to the left).

When the flowmeter ball is too high, this indicates an excess of flow is supplied to the CO detector (overpressure in the flue gas channel or the pressure from the calibration gas cylinder is too high) and a flow restrictor has to be applied.

When the flowmeter ball is too low this may indicate that the sample gas is diluted with ambient air via the bypass opening.

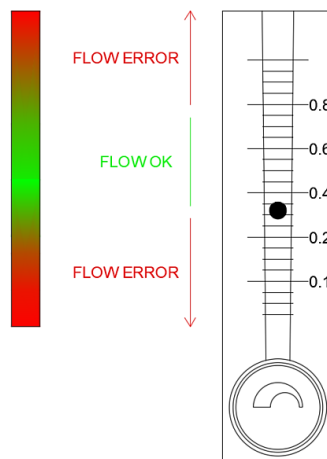

Figure 20, Flowmeter with needle valve

## **7. SENSOR CROSS SENSITIVITY**

The electrochemical CO sensor is equipped with a filter that reduces the cross sensitivity with other gases to a minimum as indicated below:

H <sub>2</sub>	Sensitivity in % of the measured gas @ 900 ppm H <sub>2</sub> in 900 ppm CO @ 10 °C:	< 2
H <sub>2</sub>	Sensitivity in % of the measured gas @ 900ppm H <sub>2</sub> in 900 ppm CO @ 20 °C:	< 5
H <sub>2</sub>	Sensitivity in % of the measured gas @ 900 ppm H <sub>2</sub> in 900 ppm CO @ 30 °C:	< 6
H <sub>2</sub> S	Sensitivity in % of the measured gas @ 20 ppm H <sub>2</sub> S:	< 0.1
NO <sub>2</sub>	Sensitivity in % of the measured gas @ 10 ppm NO <sub>2</sub> :	< 0.1
Cl <sub>2</sub>	Sensitivity in % of the measured gas @ 10 ppm Cl <sub>2</sub> :	< 0.1
NO	Sensitivity in % of the measured gas @ 50 ppm NO:	< 0.1
SO <sub>2</sub>	Sensitivity in % of the measured gas @ 20 ppm SO <sub>2</sub> :	< 0.1
C <sub>2</sub> H <sub>4</sub>	Sensitivity in % of the measured gas @ 400 ppm C <sub>2</sub> H <sub>4</sub> :	< 2
NH <sub>3</sub>	Sensitivity in % of the measured gas @ 20 ppm NH <sub>3</sub> :	< 0.1

## 8. MAINTENANCE OF THE CO DETECTOR

The following maintenance intervals are recommended for optimum operation and accurate measurements. Replacement parts can be ordered by indicating the listed product numbers. One spare filter element is included in the delivery of the system.

Maintenance	Interval	Zantingh product number
Filter element replacement	6 months	0700221
Sensor calibration	12 months	
Sensor replacement	24-36 months	0700224
Peristaltic pump replacement	60 months	0700222
Sampling pump replacement	60 months	0700223

The housing is best cleaned with a soft, lightly moistened cloth. It is advised not to use cleaning agents due to the possible release of fumes and cross sensitivity of the sensor.

### 8.1 Filter element replacement

Depending on the conditions (operating hours, composition of the sample gas, moisture content), the filter element must be periodically replaced. To replace the filter element: press the release button on the filter and turn it counterclockwise as indicated below:

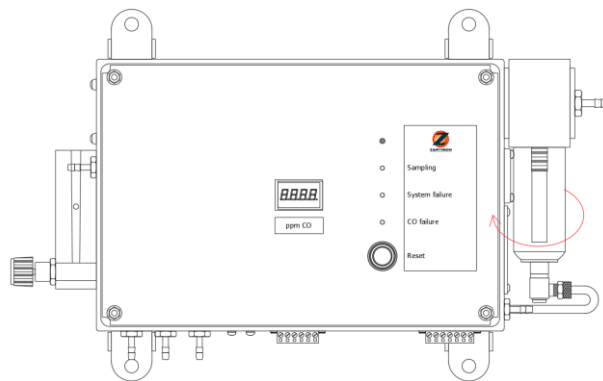

Figure 21, Sample filter

Remove the condensate trap from the filter to see the black clamping nut that keeps the filter element in place. Loosen the clamping nut to remove the filter element. Remember, only install original filter elements with the correct porosity!

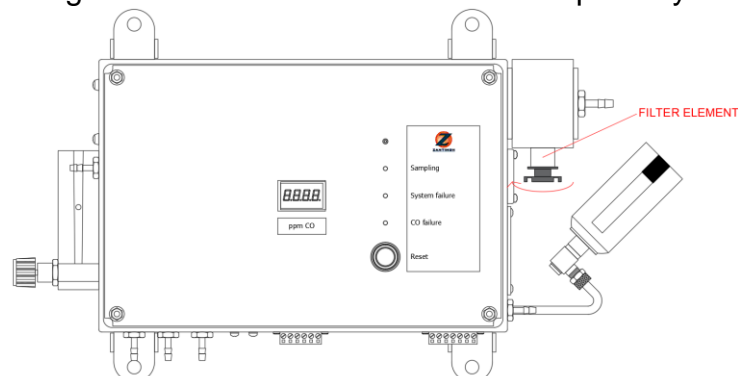
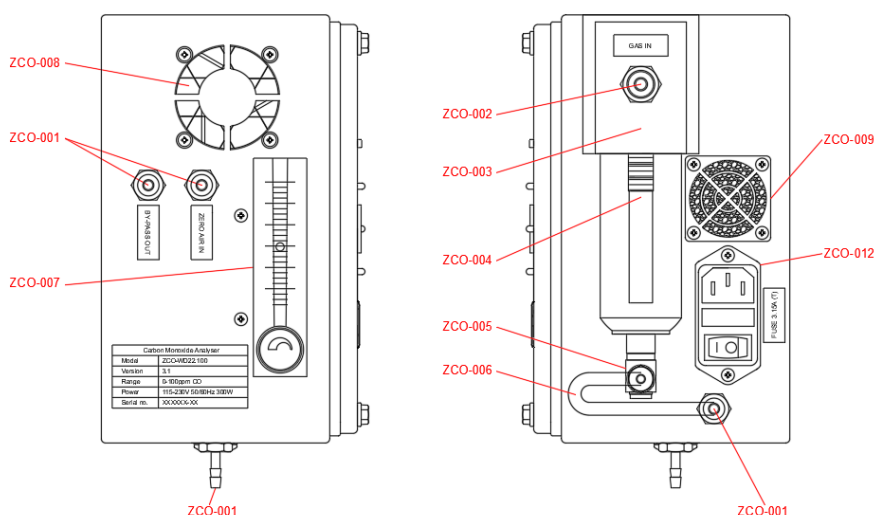

Figure 22, Removing the filter element

## 9. SPARE PARTS

Brand	Part number	Description
Zantingh	ZCO-001	G1/8" HOSE BAR
Zantingh	ZCO-002	G1/4" HOSE BAR SAMPLE GAS IN
Zantingh	ZCO-003	SAMPLE FILTER COMPLETE (INCL. FILTER ELEMENT)
Zantingh	ZCO-004	FILTER ELEMENT
Zantingh	ZCO-005	ROTATABLE G1/8" COUPLING
Zantingh	ZCO-006	DN04/06 hose connection kit
Zantingh	ZCO-007	FLOWMETER WITH NEEDLE VALVE
Zantingh	ZCO-008	FAN 50 x 50
Zantingh	ZCO-009	VENTILATION GRID INCL. FILTER MAT
Zantingh	ZCO-012	C14 CONNECTOR INCL. SWITCH AND FUSE HOLDER
Zantingh	ZCO-013	RESET SWITCH
Zantingh	ZCO-015	PERISTALTIC PUMP
Zantingh	ZCO-017	SAMPLING PUMP
Zantingh	ZCO-018	(ALARM) RELAY
Zantingh	ZCO-019	ELECTROCHEMICAL CO SENSOR
Zantingh	ZCO-023	3-WAY VALVE
Zantingh	ZCO-024	PELTIER ELEMENT
Zantingh	ZCO-025	MOUNTING FOOT (SET: 4 UNITS)
Zantingh	ZCO-026	DISPLAY
Zantingh	ZCO-027	C13 CONNECTOR
Zantingh	ZCO-030	6-POLE CABLE CONNECTOR
Zantingh	ZCO-031	7-POLE CABLE CONNECTOR
Zantingh	ZCO-032	POWER SUPPLY
Zantingh	ZCO-033	MAIN CIRCUIT BOARD
Zantingh	ZCO-034	FAN 40 x 40



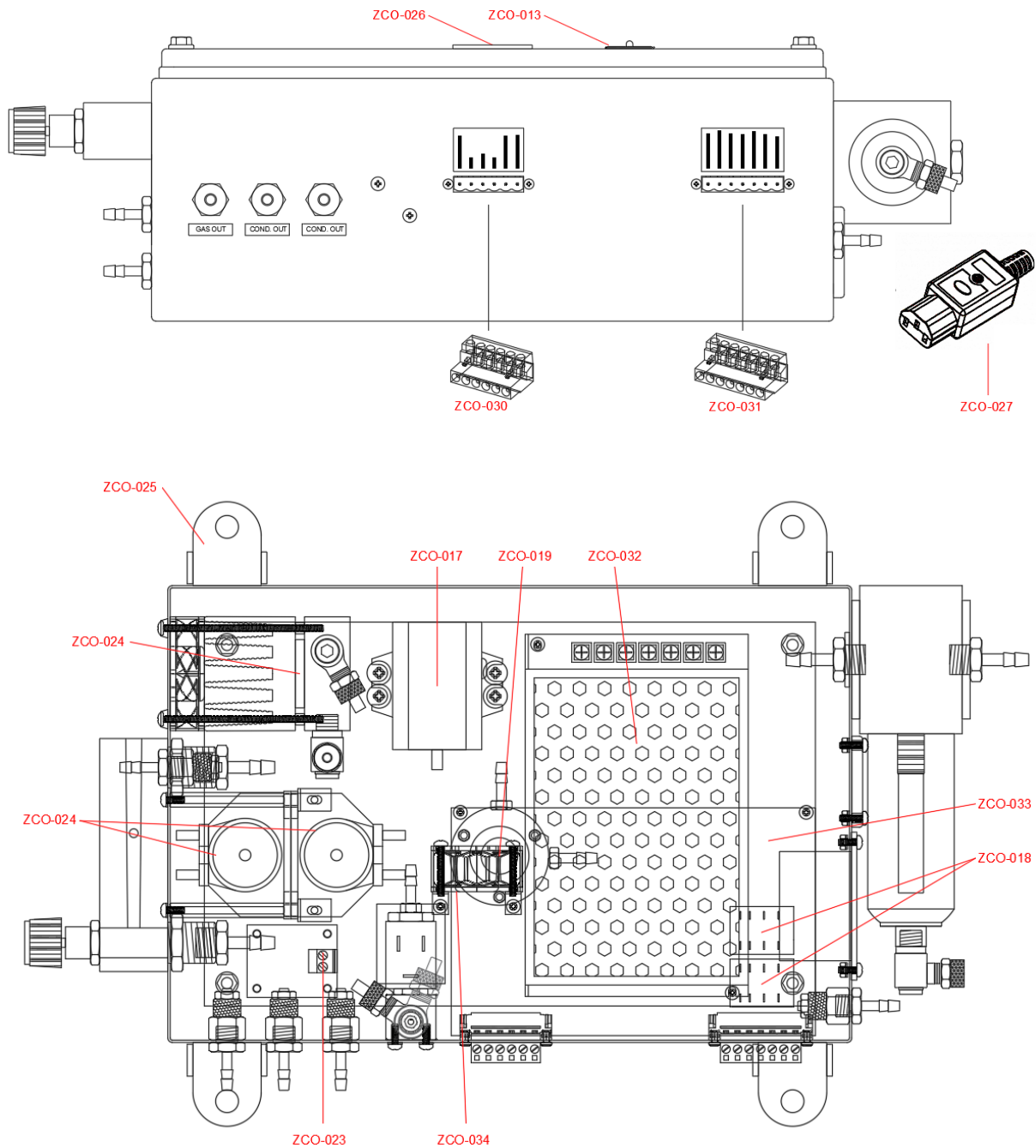

Figure 23, Various spare parts

## **10. GUARANTEE CONDITIONS**

Zantingh B.V. guarantees this Zantingh product purchased by the installer under the following conditions: The installer guarantees this product to the user under the same conditions provided below.

- 1.** The guarantee period starts on the day of delivery on site.  
The warranty has a fixed period of 12 months, based on the agreed sales price.
- 2.** A recognised installer should install the device according to the applicable general and local standards and the assembly and operation instructions provided by Zantingh.
- 3.** The system may not be moved from the location where it is originally installed.
- 4.** The guarantee becomes null and void if and when:
  - Not reporting system defects in writing to the installer and/or Zantingh B.V. immediately after these are noticed or immediately after these could have been noticed.
  - Defects or faults caused by errors, improper use by or negligence of the user who has given the order or their legal successor or caused by external causes.
  - A third party is asked to implement changes of any kind whatsoever to the system or when the user has implemented any changes whatsoever without prior written consent by the installer and/or Zantingh B.V. during the guarantee period.
  - No inspections and/or maintenance work has been performed by qualified engineers to the system when this is required during the guarantee period.
  - Corrosion caused by polluted flue gas is as determined by Zantingh B.V.If once the causes have been researched, one or more of the above conditions were initially not taken into account when registering a guarantee claim, the costs for the required research, by Zantingh B.V. or third parties, will be invoiced.
- 5.** The initial request based on the guarantee obligations described in this article should be submitted in writing to the installer within five working days after the error or defect has been observed or could reasonably have been observed.
- 6.** The stipulations included in our general sales and payment terms and conditions as issued by the FME-CWM association and registered at the district court in The Hague on 19 October 1998, number 119/1998, also apply. Zantingh B.V. cannot be held liable for any consequential damage to the Zantingh system other than a malfunction covered by the guarantee as described above. Moreover, Zantingh B.V. will not be liable for any loss of income and/or damages to the user and/or the company of any nature whatsoever.

---

**7.** Any costs incurred for assembly or disassembly, as travelling or accommodation expenses, constructional costs and such required to execute the terms of the guarantee are excluded.

Any disputes between Zantingh B.V. and the buyer regarding a claim based on the guarantee will be resolved by an expert and independent body if so required. The parties agree to abide by the binding decision of the aforementioned authority.



---

**IMPRINT**

All rights reserved, including the rights to the translations. Nothing from this issue may be copied, stored in an automatic data file or made public in any way or by any means, be it electronically, mechanically, photocopy or otherwise, without prior written consent from Zantingh B.V. Reprinting, including excerpts, is forbidden. Changes, errors and misprints reserved. These assembly and operating instructions comply with the technical requirements at the time of printing. We reserve the right to implement technical and design changes.